

FINN**HydroSeeder®****Series II****Model T60**

The FINN T60 Series II is the ideal 600 gallon HydroSeeder for the landscaper or contractor that requires a fast and economical solution for seeding jobs. FINN developed HydroSeeder technology in 1953. We've been the industry leader in quality and innovation ever since. With the FINN T60, you don't have to settle for less than proven and reliable FINN quality to tackle a wide range of demanding hydroseeding applications.

Highly Efficient. Widely Applied.

Become a one-man seeding and mulching crew. The T60 Series II covers up to 7,200 square feet per load with seed, fertilizer, and mulch in a simple, one-step process. Residential and commercial properties, sports fields, apartments, condominiums, and golf courses are all ideal ground for a T60 Series II application.

Top Design & Performance.

The FINN T60 Series II HydroSeeder features a clean, operator-friendly design. For optimum mixing efficiency the T60 Series II features hydraulically controlled paddle agitation with convenient operator controls at both the front and rear of the unit. A low machine profile allows for easy material loading and excellent stability. A large tool box in the hitch can be used for storing hose and nozzles.

Model shown includes optional equipment.

Powerfully Driven.

The T60 Series II boasts a powerful centrifugal slurry pump, driven by an in-line common shaft clutch with no high-cost maintenance couplings, drive belts or hydraulic components. This configuration dramatically increases output and operating pressure.

As the world leader for over 70 years in the design and manufacture of innovative, quality equipment for the green industry, and as the inventor of the HydroSeeder, FINN Corporation is committed to your complete satisfaction.

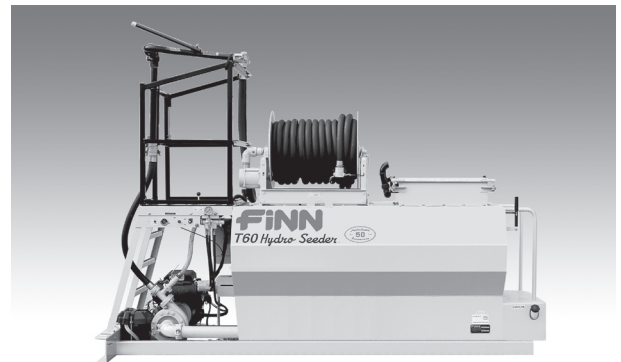



HydroSeeder®

Series II

Model T60

T60T TRAILER*

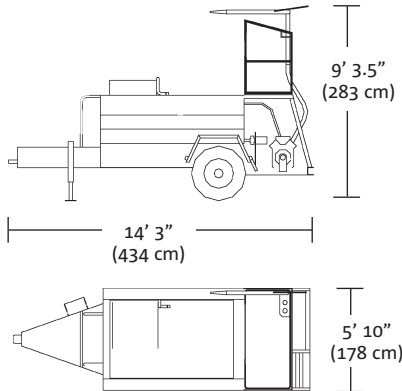

T60S SKID MOUNT

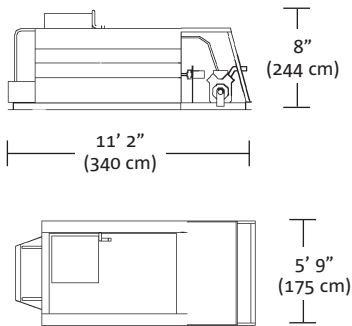

FINN MODEL T60 TECHNICAL SPECIFICATIONS

- POWER.....Kohler CH730, 25 hp (18.7 kw), 2 cylinder, OHV, air cooled gas
- ENGINE SAFETY.....Low oil pressure, high temperature shutoff SYSTEM
- TANK SIZE.....600 gallon (2,270 liter) liquid capacity, 500 gallon (1,890 liter) working capacity
- LOADS PER ACRE*.....6
- FUEL TANK.....8.2 gallon (31 liter) CAPACITY
- PUMP.....Centrifugal 3" x 1 1/2" (7.5 cm x 3.75 cm), 65 GPM @ 75 psi (245 lpm @ 5.3 kg/cm²), 3/4" (1.9 cm) solid clearance, adjustable
- PUMP DRIVE.....Direct drive through electric clutch, pump drive is independent of agitator operation
- AGITATION.....Mechanical paddle agitation and liquid recirculation
- AGITATOR DRIVE.....Reversible, variable speed hydraulic motor (0-110 rpm), with control lever at front and rear of unit
- DISCHARGE.....Up to 90 ft. (27 m) from end of discharge tower DISTANCE
- MAX. MATERIAL.....1,550 lbs. (703 kg) granular solids, CAPACITY.....200 - 250 lbs. (91 - 113 kg) fiber mulch
- NOZZLES.....(1) narrow fan, (1) wide fan, (1) long distance
- EMPTY WEIGHT.....T60T 2,770 lbs. (1,257 kg) T60S 2,170 lbs. (985 kg)
- WORKING WEIGHT*.....T60T 7,770 lbs. (3,525 kg) T60S 7,170 lbs. (3,253 kg)
- BRAKES.....Electric with break-away switch
- LIGHTS.....D.O.T., including marker, identification lights, and license plate bracket
- TIRES.....7.5" x 16" LT, load range F
- HITCH.....2 5/16" (5.87 cm) ball or heavy-duty lunette eye Includes large storage area
- HITCH WEIGHT.....Approx. 1,300 lbs. (590 kg) max load

*Tower is optional.

*Loads per acre based on an application rate of 1500 lbs. mulch/acre.

*Working weights are approximate and do not include stored materials.

FINN Corporation has a policy of continuous product improvement, and reserves the right to change design and specifications without notice.

HydroSeeder® and the FINN Design® Logo are registered trademarks of FINN Corporation.



9281 LeSaint Drive • Fairfield, OH 45014-5457
Toll Free 800.543.7166 / 513.874.2818
FINNcorp.com